



## EXTRACTE ANNEX "L"

### EQUIPAMENT DE SEGURETAT D'ÚS OBLIGATORI EN LES PROVES DE LA FEDERACIÓ CATALANA D'AUTOMOBILISME 2008

	<b>casc</b>	<b>Sota casc</b>	<b>mono</b>	<b>guants</b>	<b>calçat</b>	<b>roba interior</b>	<b>Hans</b>	<b>collarin</b>
<b>Ral-lis</b>	oblig.	oblig.	oblig.	obligatori pilot/ facultatiu copilot	oblig.	oblig. llarga	Obligatori	
<b>Ral-lis Terra</b>	oblig.	oblig.	oblig.	obligatori pilot/ facultatiu copilot	oblig.	oblig. llarga	Obligatori	
<b>Ral-lis TT</b>	oblig.	oblig.	oblig.	obligatori pilot/ facultatiu copilot	oblig.	oblig. llarga	Obligatori	
<b>Muntanya</b>	oblig.	oblig.	oblig.	oblig.	oblig.	oblig. llarga	Obligatori Excepte vehicles històrics	
<b>Autocròs</b>	oblig.	oblig.	oblig.	oblig.		oblig. llarga	Recomanat	
<b>Eslàlom</b>	oblig.		*	oblig.				
<b>Trial 4x4</b>	oblig.							
<b>Circuits</b>	oblig.	oblig.	oblig.	oblig.	oblig.	oblig. Llarga	Obligatori	
<b>Karting</b>	oblig.		oblig.**	oblig.	oblig.			
<b>Alevi-Cadet-Junior</b>	oblig.		oblig.	oblig.	oblig.			oblig.

\* Veure Reglam.Tècnic Eslàlom.

\*\* Segons normativa CIK.



## GUIA PER LA CORRECTA UTILITZACIÓ DEL SISTEMA HANS



El sistema "HANS" (retenció de cap) s'ha comprovat que es un sistema molt eficaç per retenir el cap en cas de un impacte frontal o obliqu, però s'han de tenir en conte unes consideracions importants.

- 1<sup>a</sup> La instal·lació de les bandes de les espatlles dels arnesos han de tenir un angle determinat, de 20 a 25 graus vist des de sobre i de 20 graus d'inclinació màxima cap a terra. (Veure imatge 1 i 2)
- 2<sup>a</sup> La distància màxima de les bandes de les espatlles fins als punts de subjecció no pot ser mes de 800 m/m. Per mantenir l'angle de les bandes de les espatlles consulteu el quadre n<sup>o</sup> 1.
- 3<sup>a</sup> El suport "HANS" ha de ser de la mida e inclinació adequats a cada pilot i posició del seient.
- 4<sup>a</sup> Les cintes de subjecció ancorades al casc han de ser com a màxim de 150 m/m, i completament idèntiques de llargada.
- 5<sup>a</sup> Els tensors de les bandes de les espatlles dels arnesos, han d'estar damunt del suport "HANS", a una distancia màxima de la part inferior del suport de 70 m/m. (Veure imatge 3)
- 6<sup>a</sup> El sistema "HANS" ha de complir la norma **FIA 8858/2002**.
- 7<sup>a</sup> El casc ha de ser compatible amb el sistema "HANS" segons la llista Tècnica n<sup>o</sup> 29 de la FIA i estar validat amb l'etiqueta d'identificació **FIA 8858/2002**, u homologat amb la norma **FIA 8860/2004**. (Veure imatge 4)

Imatge nº 1

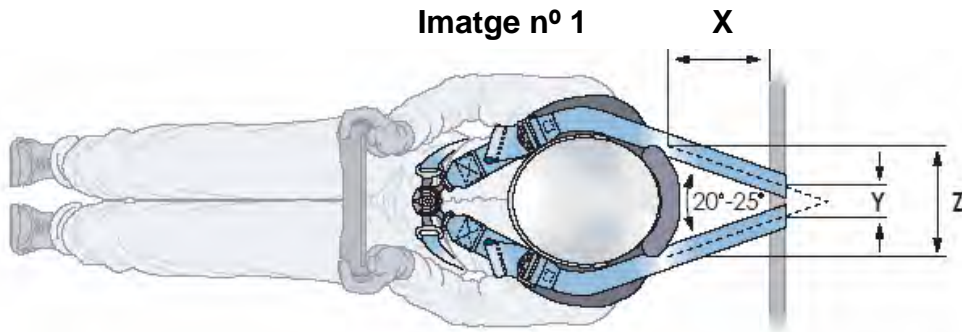

Imatge nº 2

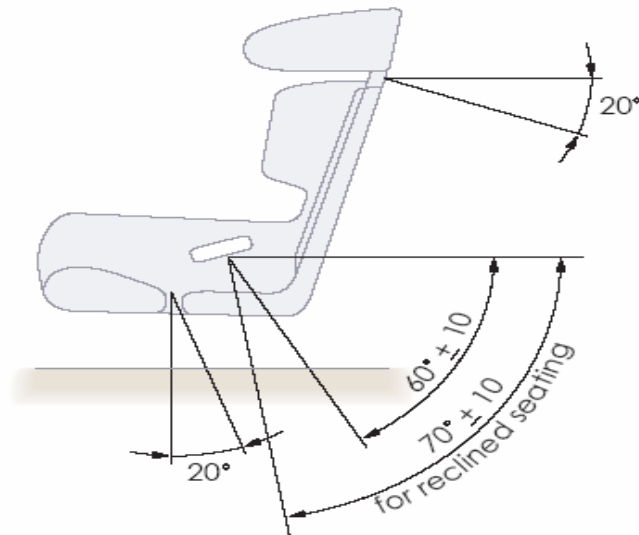

Imatge nº 3

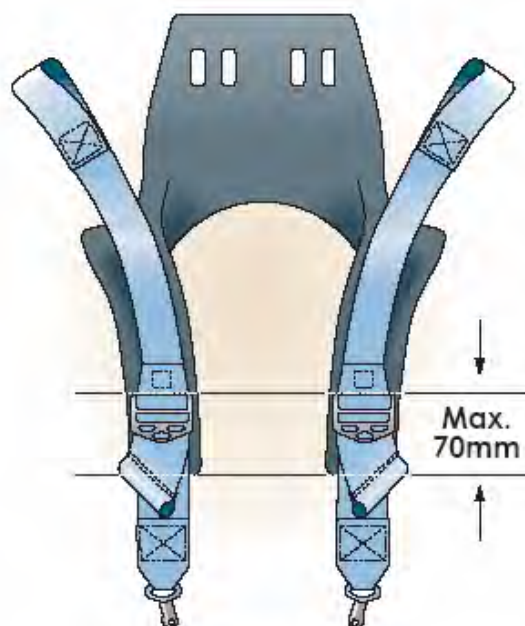



**Imatge 4**

Etiquette autocollante/ Adhesive label



**Imatge 5**

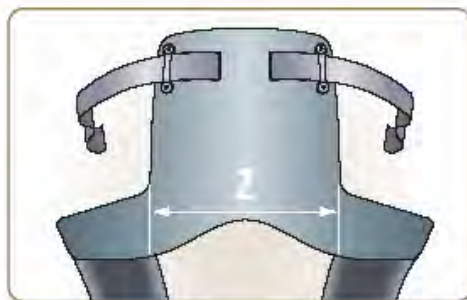

**Quadre 1**

**Table 1: Reference values for 120mm HANS Collar**

Z HANS collar width (mm)	120							
X HANS to belt anchorage (mm)	100	200	300	400	500	600	700	800
Y belt anchorage to separation (mm)	135 (110)	95 (70)	55 (30)	15 (-10)	-25 (-50)	-65 (-90)	-105 (-130)	-145 (-170)

**Table 2: Reference values for 140mm HANS Collar**

Z HANS collar width (mm)	140							
X HANS to belt anchorage (mm)	100	200	300	400	500	600	700	800
Y belt anchorage to separation (mm)	155 (130)	115 (90)	75 (50)	35 (10)	-5 (-30)	-45 (-70)	-85 (-110)	-125 (-150)

**Table 3: Reference values for 160mm HANS Collar**

Z HANS collar width (mm)	160							
X HANS to belt anchorage (mm)	100	200	300	400	500	600	700	800
Y belt anchorage to separation (mm)	175 (150)	135 (110)	95 (70)	55 (30)	15 (-10)	-25 (-50)	-65 (-90)	-105 (-130)

**Table 4: Reference values for 180mm HANS Collar**

Z HANS collar width (mm)	180							
X HANS to belt anchorage (mm)	100	200	300	400	500	600	700	800
Y belt anchorage to separation (mm)	195 (170)	155 (130)	115 (90)	75 (50)	35 (10)	-5 (-30)	-45 (-70)	-85 (-110)



**Nota.** Els números vermells, vol dir que les bandes de 75 m/m de les espatlles es sobreposen, i amb indicador – (negatiu) vol dir que es creuen.

La mesura indicada és la separació entre els centres de les bandes del arnes de seguretat de les espatlles.

(Els valors entre parèntesi, es per bandes de 50 m/m)

### **Definició dels valors indicats en les imatges 1 i 5 i el quadre 1.**

- Z** Amplada del Hans, mesurada tal com es representa en la imatge 5.
- X** Distància des de l'extrem posterior de la superfície de contacte de la banda del arnes amb el Hans fins el punt d'ancoratge en el vehicle de les bandes.
- Y** Separació dels centres de les bandes de les espatlles en els punts d'ancoratge en el vehicle.  
Aquesta separació ajudarà a mantenir l'angle entre les dues bandes que fa que les bandes del arnes no vagin a l'exterior.

Per més informació us podeu adreçar a la Comissió Tècnica de la FCA,  
[tecnic@fca.cat](mailto:tecnic@fca.cat)

**NORMES RECONNUES POUR LES CASQUES  
RECOGNISED STANDARDS FOR HELMETS**

**LISTE TECHNIQUE N° 25 / TECHNICAL LIST N° 25**

• **FIA 8860-2004**

Fédération International de l'Automobile  
8, place de la concorde  
75008 Paris  
France.

Web site: [www.fia.com](http://www.fia.com)

Etiquette autocollante/ Adhesive label



• **Snell SA 2005**  
• **Snell SA 2000**

Snell Memorial Foundation  
3628 Madison Avenue, Suite 11  
North Highlands, CA 95660  
USA.

Web site: [www.smf.org](http://www.smf.org)

Etiquette tissu ou autocollante/ Cloth or adhesive label



• **SFI 31.1A**  
• **SFI 31.2A**

SFI Foundation Inc  
15708 Pomerado Road, Suite N208  
Poway, CA 92064  
USA

Web site: [www.sfifoundation.com](http://www.sfifoundation.com)

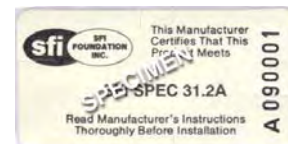

• **BS6658-85 type A/FR**

British Standards Institution  
389 Chiswick High Road  
London  
W4 4AL- UK  
Web site: [www.bsi-global.com](http://www.bsi-global.com)



**Pour Autocross-division 3 UNIQUEMENT, les normes suivantes sont aussi reconnues:**  
**For Autocross-division 3 ONLY, the following standards are also recognised:**

• **Snell M 2000**  
• **Snell M 95**

Etiquette tissu ou autocollante/ Cloth or adhesive label



**LISTE DES SYSTEMES HANS® APPROUVES SELON LA NORME FIA 8858-2002 ET DES  
CASQUES COMPATIBLES**  
**LIST OF FIA-APPROVED HANS® SYSTEMS ACCORDING TO FIA STANDARD 8858-2002 AND  
COMPATIBLE HELMETS**













**LISTE TECHNIQUE N° 29 / TECHNICAL LIST N° 29**

- Partie 1 / Part 1:** HANS® approuvés selon FIA 8858-2002 / *Approved HANS® according to FIA 8858-2002*  
**Partie 2 / Part 2:** Casques compatibles avec les HANS® / *Approved helmets compatible with HANS®*  
**Partie 3 / Part 3:** Système de sangle du HANS® approuvés selon FIA 8858-2002  
 / *HANS® tether system approved according to FIA 8858-2002*













-----  
**Partie 1/ Part 1**  
**HANS® approuvés selon FIA 8858-2002**  
**Approved HANS® according to FIA 8858-2002**

HANS® approuvés selon FIA 8858-2002 <sup>(1)</sup> Approved HANS® according to FIA 8858-2002 <sup>(1)</sup>		
Nom du modèle <i>Model</i>	Constructeur <i>Manufacturer</i>	Etiquette <i>Label</i>
<b>20RE</b> with a S/N as from 3680	Hubbard/Downing Inc	 In compliance with FIA standard 8858-2002 Manufacturer: Hubbard Downing, Inc. Model: 20RE
<b>20RP</b> with a S/N as from 3850	Hubbard/Downing Inc	 In compliance with FIA standard 8858-2002 Manufacturer: Hubbard Downing, Inc. Model: 20RP label printed on metallic paper
<b>20SP</b> with a S/N as from 4685	Hubbard/Downing Inc	 In compliance with FIA standard 8858-2002 Manufacturer: Hubbard Downing, Inc. Model: 20SP label printed on metallic paper
<b>30.1 DeMatta</b>	Hubbard/Downing Inc	 In compliance with FIA standard 8858-2002 Manufacturer: Hubbard Downing, Inc. Model: 30.1 DeMatta
<b>30RE</b> with a S/N as from 3670	Hubbard/Downing Inc	 In compliance with FIA standard 8858-2002 Manufacturer: Hubbard Downing, Inc. Model: 30RE
<b>30RP</b> with a S/N as from 3616	Hubbard/Downing Inc	 In compliance with FIA standard 8858-2002 Manufacturer: Hubbard Downing, Inc. Model: 30RP
<b>30RP WIDE</b> with a S/N as from 3608	Hubbard/Downing Inc	 In compliance with FIA standard 8858-2002 Manufacturer: Hubbard Downing, Inc. Model: 30RP WIDE













<sup>(1)</sup> Consultez l'Annexe L- Chapitre III- Article 1.2 du Code Sportif International pour les détails  
 Please refer to Appendix L – Chapter III – Article 1.2. of the International Sporting Code for details

<b>HANS® approuvés selon FIA 8858-2002 <sup>(1)</sup></b> <b>Approved HANS® according to FIA 8858-2002 <sup>(1)</sup></b>		
Nom du modèle <i>Model</i>	Constructeur <i>Manufacturer</i>	Etiquette <i>Label</i>
<b>30RP Wide +10</b>	Hubbard/Downing Inc	 In compliance with <b>FIA standard 8858-2002</b> Manufacturer: <b>Hubbard Downing, Inc.</b> Model: <b>30RP WIDE +10</b>
<b>30RP Wide +20</b>	Hubbard/Downing Inc	 In compliance with <b>FIA standard 8858-2002</b> Manufacturer: <b>Hubbard Downing, Inc.</b> Model: <b>30RP WIDE +20</b>
<b>40RP</b> with a S/N as from 3005	Hubbard/Downing Inc	 In compliance with <b>FIA standard 8858-2002</b> Manufacturer: <b>Hubbard Downing, Inc.</b> Model: <b>40RP</b>
<b>10M Economy</b>	Hubbard/Downing Inc HANS® Performance Products	 In compliance with <b>FIA standard 8858-2002</b> Manufacturer: <b>HANS®</b> <b>Performance Products</b> Model: <b>10M Economy</b>
<b>10M Extra</b>	Hubbard/Downing Inc HANS® Performance Products	 In compliance with <b>FIA standard 8858-2002</b> Manufacturer: <b>HANS</b> <b>Performance Products</b> Model: <b>10M Extra</b>
<b>20XS Economy</b>	Hubbard/Downing Inc HANS® Performance Products	 In compliance with <b>FIA standard 8858-2002</b> Manufacturer: <b>HANS®</b> <b>Performance Products</b> Model: <b>20XS Economy</b>
<b>20XS Extra</b>	Hubbard/Downing Inc HANS® Performance Products	 In compliance with <b>FIA standard 8858-2002</b> Manufacturer: <b>HANS</b> <b>Performance Products</b> Model: <b>20XS Extra</b>
<b>20S Economy</b>	Hubbard/Downing Inc HANS® Performance Products	 In compliance with <b>FIA standard 8858-2002</b> Manufacturer: <b>HANS®</b> <b>Performance Products</b> Model: <b>20S Economy</b>
<b>20S Extra</b>	Hubbard/Downing Inc HANS® Performance Products	 In compliance with <b>FIA standard 8858-2002</b> Manufacturer: <b>HANS</b> <b>Performance Products</b> Model: <b>20S Extra</b>
<b>20M Professional</b>	Hubbard/Downing Inc HANS® Performance Products	 In compliance with <b>FIA standard 8858-2002</b> Manufacturer: <b>HANS®</b> <b>Performance Products</b> Model: <b>20M Professional</b>
<b>20L Economy</b>	Hubbard/Downing Inc HANS® Performance Products	 In compliance with <b>FIA standard 8858-2002</b> Manufacturer: <b>HANS®</b> <b>Performance Products</b> Model: <b>20L Economy</b>
<b>20L Extra</b>	Hubbard/Downing Inc HANS® Performance Products	 In compliance with <b>FIA standard 8858-2002</b> Manufacturer: <b>HANS</b> <b>Performance Products</b> Model: <b>20L Extra</b>















<sup>(1)</sup> Consultez l'Annexe L- Chapitre III- Article 1.2 du Code Sportif International pour les détails  
 Please refer to Appendix L – Chapter III – Article 1.2. of the International Sporting Code for details

<b>HANS® approuvés selon FIA 8858-2002 <sup>(1)</sup></b> <b>Approved HANS® according to FIA 8858-2002 <sup>(1)</sup></b>		
Nom du modèle <i>Model</i>	Constructeur <i>Manufacturer</i>	Etiquette <i>Label</i>
<b>20L Professional</b>	Hubbard/Downing Inc HANS® Performance Products	 <b>In compliance with FIA standard 8858-2002</b> Manufacturer: <b>HANS® Performance Products</b> Model: <b>20L Professional</b>
<b>30M Economy</b>	Hubbard/Downing Inc HANS® Performance Products	 <b>In compliance with FIA standard 8858-2002</b> Manufacturer: <b>HANS® Performance Products</b> Model: <b>30M Economy</b>
<b>30M Extra</b>	Hubbard/Downing Inc HANS® Performance Products	 <b>In compliance with FIA standard 8858-2002</b> Manufacturer: <b>HANS Performance Products</b> Model: <b>30M Extra</b>
<b>30M Professional</b>	Hubbard/Downing Inc HANS® Performance Products	 <b>In compliance with FIA standard 8858-2002</b> Manufacturer: <b>HANS® Performance Products</b> Model: <b>30M Professional</b>
<b>30L Professional</b>	Hubbard/Downing Inc HANS® Performance Products	 <b>In compliance with FIA standard 8858-2002</b> Manufacturer: <b>HANS® Performance Products</b> Model: <b>30L Professional</b>
<b>30L Economy</b>	Hubbard/Downing Inc HANS® Performance Products	 <b>In compliance with FIA standard 8858-2002</b> Manufacturer: <b>HANS® Performance Products</b> Model: <b>30L Economy</b>
<b>30L Extra</b>	Hubbard/Downing Inc HANS® Performance Products	 <b>In compliance with FIA standard 8858-2002</b> Manufacturer: <b>HANS Performance Products</b> Model: <b>30L Extra</b>
<b>40M Professional</b>	Hubbard/Downing Inc HANS® Performance Products	 <b>In compliance with FIA standard 8858-2002</b> Manufacturer: <b>HANS® Performance Products</b> Model: <b>40M Professional</b>
<b>20M PRO</b> with a S/N as from 3850 or as from 2MP0001	Schroth	 <b>In compliance with FIA standard 8858-2002</b> Manufacturer: <b>SCHROTH Safety Products</b> Model: <b>20M PRO</b>
<b>20M SPORT</b> with a S/N as from 3680 or as from 2MS0001	Schroth	 <b>In compliance with FIA standard 8858-2002</b> Manufacturer: <b>SCHROTH Safety Products</b> Model: <b>20M SPORT</b>
<b>20L SPORT</b> with a S/N as from 20LS0001	Schroth	 <b>In compliance with FIA standard 8858-2002</b> Manufacturer: <b>SCHROTH Safety Products</b> Model: <b>20L SPORT</b>













<sup>(1)</sup> Consultez l'Annexe L- Chapitre III- Article 1.2 du Code Sportif International pour les détails  
 Please refer to Appendix L – Chapter III – Article 1.2. of the International Sporting Code for details

<b>HANS® approuvés selon FIA 8858-2002 <sup>(1)</sup></b> <b>Approved HANS® according to FIA 8858-2002 <sup>(1)</sup></b>		
<b>Nom du modèle</b> <i>Model</i>	<b>Constructeur</b> <i>Manufacturer</i>	<b>Etiquette</b> <i>Label</i>
<b>20L PRO</b> with a S/N as from 2LP0002	Schroth	 In compliance with FIA standard 8858-2002 Manufacturer: <b>SCHROTH Safety Products</b> Model: 20L Pro
<b>30M PRO</b> with a S/N as from 3616 or as from 3MP0004	Schroth	 In compliance with FIA standard 8858-2002 Manufacturer: <b>SCHROTH Safety Products</b> Model: 30M PRO
<b>30L PRO</b>	Schroth	 In compliance with FIA standard 8858-2002 Manufacturer: <b>SCHROTH Safety Products</b> Model: 30L Pro
<b>30M SPORT</b> with a S/N as from 3670 or as from 3MS0006	Schroth	 In compliance with FIA standard 8858-2002 Manufacturer: <b>SCHROTH Safety Products</b> Model: 30M SPORT
<b>40F1- AW</b> with a S/N as from 4MFAW0003	Schroth	 In compliance with FIA standard 8858-2002 Manufacturer: <b>SCHROTH Safety Products</b> Model: 40F1 - AW
<b>40M F1</b> with a S/N as from 3005 or as from 4MF0003	Schroth	 In compliance with FIA standard 8858-2002 Manufacturer: <b>SCHROTH Safety Products</b> Model: 40M F1
<b>40M PRO</b> with a S/N as from 3005	Schroth	 In compliance with FIA standard 8858-2002 Manufacturer: <b>SCHROTH Safety Products</b> Model: 40M PRO
<b>Economy Medium 10</b>	Stand 21 Racewear	 In compliance with FIA Standard 8858-2002 En conformité avec la norme FIA 8858-2002 Manufacturer/Fabricant: <b>Stand 21 Racewear®</b> Model/Modèle: <b>Economy Medium 10</b>
<b>Economy Small 20</b>	Stand 21 Racewear	 In compliance with FIA Standard 8858-2002 En conformité avec la norme FIA 8858-2002 Manufacturer/Fabricant: <b>Stand 21 Racewear®</b> Model/Modèle: <b>Economy Small 20</b>
<b>Premium Medium 20</b>	Stand 21 Racewear	 In compliance with FIA Standard 8858-2002 En conformité avec la norme FIA 8858-2002 Manufacturer/Fabricant: <b>Stand 21 Racewear®</b> Model/Modèle: <b>Premium Medium 20</b>
<b>Economy Medium 20</b>	Stand 21 Racewear	 In compliance with FIA Standard 8858-2002 En conformité avec la norme FIA 8858-2002 Manufacturer/Fabricant: <b>Stand 21 Racewear®</b> Model/Modèle: <b>Economy Medium 20</b>
<b>Economy Large 20</b>	Stand 21 Racewear	 In compliance with FIA Standard 8858-2002 En conformité avec la norme FIA 8858-2002 Manufacturer/Fabricant: <b>Stand 21 Racewear®</b> Model/Modèle: <b>Economy Large 20</b>

<sup>(1)</sup> Consultez l'Annexe L- Chapitre III- Article 1.2 du Code Sportif International pour les détails  
Please refer to Appendix L – Chapter III – Article 1.2. of the International Sporting Code for details

<b>HANS® approuvés selon FIA 8858-2002 <sup>(1)</sup></b> <b>Approved HANS® according to FIA 8858-2002 <sup>(1)</sup></b>		
Nom du modèle <i>Model</i>	Constructeur <i>Manufacturer</i>	Etiquette <i>Label</i>
Premium Large 20	Stand 21 Racewear	 In compliance with FIA Standard 8858-2002 En conformité avec la norme FIA 8858-2002 Manufacturer/Fabricant: Stand 21 Racewear® Model/Modèle: Premium Large 20
Economy Small 25	Stand 21 Racewear	 In compliance with FIA Standard 8858-2002 En conformité avec la norme FIA 8858-2002 Manufacturer/Fabricant: Stand 21 Racewear® Model/Modèle: Economy Small 25
Economy Medium 30	Stand 21 Racewear	 In compliance with FIA Standard 8858-2002 En conformité avec la norme FIA 8858-2002 Manufacturer/Fabricant: Stand 21 Racewear® Model/Modèle: Economy Medium 30
Premium Medium 30	Stand 21 Racewear	 In compliance with FIA Standard 8858-2002 En conformité avec la norme FIA 8858-2002 Manufacturer/Fabricant: Stand 21 Racewear® Model/Modèle: Premium Medium 30
Economy Large 30	Stand 21 Racewear	 In compliance with FIA Standard 8858-2002 En conformité avec la norme FIA 8858-2002 Manufacturer/Fabricant: Stand 21 Racewear® Model/Modèle: Economy Large 30
Premium Large 30	Stand 21 Racewear	 In compliance with FIA Standard 8858-2002 En conformité avec la norme FIA 8858-2002 Manufacturer/Fabricant: Stand 21 Racewear® Model/Modèle: Premium Large 30
Premium Medium 40	Stand 21 Racewear	 In compliance with FIA Standard 8858-2002 En conformité avec la norme FIA 8858-2002 Manufacturer/Fabricant: Stand 21 Racewear® Model/Modèle: Premium Medium 40
10 Medium Pro	Stand 21 Racewear	 In compliance with FIA Standard 8858-2002 Manufacturer: <b>stand21</b> Model: 10 Medium Pro
20 Small Pro	Stand 21 Racewear	 In compliance with FIA Standard 8858-2002 Manufacturer: <b>stand21</b> Model: 20 Small Pro
20 Medium Hi-Tec	Stand 21 Racewear	 In compliance with FIA Standard 8858-2002 Manufacturer: <b>stand21</b> Model: 20 Medium Hi-Tec
20 Medium Pro	Stand 21 Racewear	 In compliance with FIA Standard 8858-2002 Manufacturer: <b>stand21</b> Model: 20 Medium Pro
20 Large Pro	Stand 21 Racewear	 In compliance with FIA Standard 8858-2002 Manufacturer: <b>stand21</b> Model: 20 Large Pro
20 Large Hi-Tec	Stand 21 Racewear	 In compliance with FIA Standard 8858-2002 Manufacturer: <b>stand21</b> Model: 20 Large Hi-Tec

<sup>(1)</sup> Consultez l'Annexe L- Chapitre III- Article 1.2 du Code Sportif International pour les détails  
 Please refer to Appendix L – Chapter III – Article 1.2. of the International Sporting Code for details

<b>HANS® approuvés selon FIA 8858-2002 <sup>(1)</sup></b> <b>Approved HANS® according to FIA 8858-2002 <sup>(1)</sup></b>		
Nom du modèle <i>Model</i>	Constructeur <i>Manufacturer</i>	Etiquette <i>Label</i>
25 X-Small Pro	Stand 21 Racewear	 In compliance with FIA Standard 8858-2002 Manufacturer: <b>stand21</b> Model: 25 X-Small Pro
30 Medium Pro	Stand 21 Racewear	 In compliance with FIA Standard 8858-2002 Manufacturer: <b>stand21</b> Model: 30 Medium Pro
30 Medium Hi-Tec	Stand 21 Racewear	 In compliance with FIA Standard 8858-2002 Manufacturer: <b>stand21</b> Model: 30 Medium Hi-Tec
30 Large Pro	Stand 21 Racewear	 In compliance with FIA Standard 8858-2002 Manufacturer: <b>stand21</b> Model: 30 Large Pro
30 Large Hi tec	Stand 21 Racewear	 In compliance with FIA Standard 8858-2002 Manufacturer: <b>stand21</b> Model: 30 Large Hi-Tec
40 Medium Hi-Tec	Stand 21 Racewear	 In compliance with FIA Standard 8858-2002 Manufacturer: <b>stand21</b> Model: 40 Medium Hi-Tec
30 MS Hi-Tec F1	Stand 21 Racewear	 In compliance with FIA Standard 8858-2002 Manufacturer: <b>stand21</b> Model: 30 MS Hi-Tec F1
TRULLI MK1, 000-71-10059	Renault	 In compliance with FIA standard 8858-2002 Manufacturer: <b>RENAULT F1 Team</b> Model: Trulli MK1, 000-71-10059
ALONSO MK1, 000-71-10052	Renault	 In compliance with FIA standard 8858-2002 Manufacturer: <b>RENAULT F1 Team</b> Model: Alonso MK1, 000-71-10052
ALONSO MK2F, 000-71-10078	Renault	 In compliance with FIA standard 8858-2002 Manufacturer: <b>RENAULT F1 Team</b> Model: Alonso MK2F, 000-71-10078
TRULLI MK2B, 000-071-10080	Renault	 In compliance with FIA standard 8858-2002 Manufacturer: <b>RENAULT F1 Team</b> Model: Trulli MK2B, 000-71-10080
MS Exp00 Prog02	Ferrari	TBA
RB. Exp00 Prog02	Ferrari	TBA
HANS-002	Jaguar	TBA
C2113-0044/04	Sauber	TBA
C2213-1162#01	Sauber	TBA
TMG Toyota-001	Toyota	TBA

<sup>(1)</sup> Consultez l'Annexe L- Chapitre III- Article 1.2 du Code Sportif International pour les détails  
 Please refer to Appendix L – Chapter III – Article 1.2. of the International Sporting Code for details

**Partie 2 / Part 2**  
**CASQUES COMPATIBLES AVEC LE HANS®**  
**APPROVED HELMETS COMPATIBLE WITH HANS®**

Lorsque le montage des ancrages de sangles pour le Hans® a été effectué sous la conduite du fabricant de casques lui-même, les casques arborent une étiquette FIA holographique argentée brillante (fig 1)

*When the mounting of the tether anchorages for the Hans® has been carried out under the supervision of the helmet manufacturer himself, the helmets carry a glossy silver holographic FIA label (fig-1).*



Fig 1 – Etiquette permettant d'identifier les casques équipés dès l'origine des inserts Hans®.  
 Fig 1 – Label for identifying helmets originally equipped with Hans® inserts.

<b>Casques compatibles avec le HANS® selon FIA 8858-2002 <sup>(2)</sup></b> <b>Approved helmets compatible with HANS® according to FIA 8858-2002 <sup>(2)</sup></b>			
Nom du modèle <i>Model name</i>	Constructeur <i>Manufacturer</i>	Norme de certification <i>Helmet certification standard</i>	Commentaires <i>Comments</i>
GP5	Arai	Snell 2000 / 2005	
GP-5K GP-5S	Arai	Snell 2000 / 2005	
GP-J2 GP-Jet/f	Arai	Snell 2000 / 2005	Casque ouvert Open face helmet
GP-5RC	Arai	Snell 2000 / 2005	
GP-5W	Arai	Snell 2005	
M3	Bell Racing Europe	Snell 2000	
KF1-Ultra	Bell Racing Europe	Snell 2000 / 2005	
Vortex	Bell Racing Europe	Snell 2000	
Vortex Forced Air	Bell Racing Europe	Snell 2000	
Sport 3	Bell Racing Europe	Snell 2000	
MAG 4	Bell Racing Europe	Snell 2000	Casque ouvert Open face helmet
K1 Sport SV	Bell Racing Europe	Snell 2000 with manufacturing date from 03/2005 and Snell 2005	
KF1 Ultra SV	Bell Racing Europe	Snell 2000 with manufacturing date from 03/2005 and Snell 2005	
M4 Ultra	Bell Racing Europe	Snell 2000 with manufacturing date from 03/2005 and Snell 2005	

<sup>(2)</sup> L'utilisation des modèles HANS approuvés, avec les modèles de casques figurant ci-dessus, est conforme à l'Annexe L – Chapitre III – Article 1.2. du Code Sportif International. Les casques homologués selon la norme FIA 8860-2004 sont d'office compatibles avec le système HANS et ne sont donc pas listés ici.

*The use of the approved HANS models, with the helmet models as listed above, complies with Appendix L – Chapter III – Article 1.2. of the International Sporting Code. Helmets homologated according to the standard FIA 8860-2004 are compatible with the HANS system as a matter of course and are therefore not listed here.*

<sup>(1)</sup> Consultez l'Annexe L- Chapitre III- Article 1.2 du Code Sportif International pour les détails  
*Please refer to Appendix L – Chapter III – Article 1.2. of the International Sporting Code for details*

<b>Casques compatibles avec le HANS<sup>®</sup> selon FIA 8858-2002 <sup>(2)</sup></b> <b>Approved helmets compatible with HANS<sup>®</sup> according to FIA 8858-2002 <sup>(2)</sup></b>			
			
Nom du modèle <i>Model name</i>	Constructeur <i>Manufacturer</i>	Norme de certification <i>Helmet certification standard</i>	Commentaires <i>Comments</i>
Sport 4	Bell Racing Europe	Snell 2000 with manufacturing date from 03/2005 and Snell 2005	
RS3 Ultra	Bell Racing Europe	Snell 2000 / Snell 2005	
RS3 Sport	Bell Racing Europe	Snell 2000 / Snell 2005	
MAG 6	Bell Racing Europe	Snell 2005	Casque ouvert Open face helmet
Vortex 2	Bell Racing Europe	Snell 2005	
Predator	Composites Bieffe	Snell 2000	
Draft	Impact Race Products	Snell 2005	
Vapor	Impact Race Products	Snell 2005	
Sparco Pro Rally HANS Peltor G77 HANS Peltor G7 HANS Sabelt Trophy Hans	MAVET	BSI 6658-1985	Casque ouvert Open face helmet
Sparco Pro jet HANS Sabelt Jet Hans	MAVET	BSI 6658-1985	Casque ouvert Open face helmet
Sparco Formula Peltor G90	MAVET	Snell 2000	
Sparco Rally plus Hans Sparco Formula Hans Sparco Formula Mc-Laren Mercedes Peltor G90 Hans	MAVET	BSI 6658-1985	
Sparco SPY05	MAVET	Snell 2005	
MQ3	MAVET	BSI 6658-1985	Casque ouvert Open face helmet
SP140	MAVET	Snell 2005	
OMP Jet 4 Hans Intercom OMP Jet 4 Hans OMP Jet 4	MAVET	BSI 6658-1985	Casque ouvert Open face helmet
OMP Formula 4 Hans OMP Formula 4 Hans Intercom Hans OMP Formula 4	MAVET	BSI 6658-1985	
OMP Turismo 4 Hans OMP Turismo 4 Hans Intercom OMP Turismo 4	MAVET	BSI 6658-1985	
MQ1 EVO HANS SNELL	MAVET	Snell 2005	
OMP Grand Prix OMP Speed	MAVET	Snell 2005	
Speedway Shark	Schroth / Simpson	Snell 2000 / 2005	
Super Voyager	Schroth /Simpson	Snell 2000 / 2005	

<sup>(2)</sup> L'utilisation des modèles HANS approuvés, avec les modèles de casques figurant ci-dessus, est conforme à l'Annexe L – Chapitre III – Article 1.2. du Code Sportif International. Les casques homologués selon la norme FIA 8860-2004 sont d'office compatibles avec le système HANS et ne sont donc pas listés ici.

*The use of the approved HANS models, with the helmet models as listed above, complies with Appendix L – Chapter III – Article 1.2. of the International Sporting Code. Helmets homologated according to the standard FIA 8860-2004 are compatible with the HANS system as a matter of course and are therefore not listed here.*

<sup>(1)</sup> Consultez l'Annexe L- Chapitre III- Article 1.2 du Code Sportif International pour les détails  
*Please refer to Appendix L – Chapter III – Article 1.2. of the International Sporting Code for details*

**Casques compatibles avec le HANS<sup>®</sup> selon FIA 8858-2002 <sup>(2)</sup>**  
**Approved helmets compatible with HANS<sup>®</sup> according to FIA 8858-2002 <sup>(2)</sup>**



Nom du modèle <i>Model name</i>	Constructeur <i>Manufacturer</i>	Norme de certification <i>Helmet certification standard</i>	Commentaires <i>Comments</i>
QF 1.1	Schuberth	Snell 2000	
Q2	Schuberth	Snell 2000	
RF 1	Schuberth Engineering	Snell 2000	
RF 1.1	Schuberth Engineering	Snell 2000	
RF 1.1 (Trimmed)	Schuberth Engineering	Snell 2000	
RF1.3	Schuberth Engineering	Snell 2000	
RF1.4	Schuberth Engineering	Snell 2000	
RS4	Shark Helmets	Snell 2005	
WTT Evo/TK	Sparco /APC	Snell 2000	
WTT Evo/F1	Sparco / APC	Snell 2000	
WTT Evo/KF	Sparco / APC	Snell 2000	
WTT-J	Sparco / APC	Snell 2000 / 2005	Casque ouvert Open face helmet
WTT Evo/TK	Sparco / OSBE	Snell 2000	
WTT Evo/F1	Sparco / OSBE	Snell 2000	
WTT Evo/KF	Sparco / OSBE	Snell 2000	
WTT-J	Sparco / OSBE	Snell 2000 / 2005	Casque ouvert Open face helmet
F21	Stand 21	Snell 2000 / 2005	
CH17	Stand 21	Snell 2000 / 2005	Casque ouvert Open face helmet
AF 21	Stand 21	Snell 2000 / 2005	
J12/F1	Suomy	Snell 2000 / 2005	
WTT F1	Tesi -Sparco	Snell 2000	
FP1	UVEX	Snell 2000 / 2005	
FP2	UVEX	Snell 2000 / 2005	
FP3	UVEX	Snell 2005	
Stilo SP3 (Snell)	Vemar Helmets	Snell 2000	
Stilo SP3 (BSI)	Vemar Helmets	BSI 6658-1985	
Stilo SP3 with SEA system	Vemar Helmets	BSI 6658-1985/Snell 2000	
Stilo SR3 (Snell)	Vemar Helmets	<b><u>Snell 2000 only</u></b>	
Stilo SR3 (BSI)	Vemar Helmets	BSI 6658-1985	
Stilo SR3	Vemar Helmets	BSI 6658-1985/Snell 2000	

<sup>(2)</sup> L'utilisation des modèles HANS approuvés, avec les modèles de casques figurant ci-dessus, est conforme à l'Annexe L – Chapitre III – Article 1.2. du Code Sportif International. Les casques homologués selon la norme FIA 8860-2004 sont d'office compatibles avec le système HANS et ne sont donc pas listés ici.

*The use of the approved HANS models, with the helmet models as listed above, complies with Appendix L – Chapter III – Article 1.2. of the International Sporting Code. Helmets homologated according to the standard FIA 8860-2004 are compatible with the HANS system as a matter of course and are therefore not listed here.*

<sup>(1)</sup> Consultez l'Annexe L- Chapitre III- Article 1.2 du Code Sportif International pour les détails

*Please refer to Appendix L – Chapter III – Article 1.2. of the International Sporting Code for details*

<b>Casques compatibles avec le HANS<sup>®</sup> selon FIA 8858-2002 <sup>(2)</sup></b> <b>Approved helmets compatible with HANS<sup>®</sup> according to FIA 8858-2002 <sup>(2)</sup></b>			
Nom du modèle <i>Model name</i>	Constructeur <i>Manufacturer</i>	Norme de certification <i>Helmet certification standard</i>	Commentaires <i>Comments</i>
with SEA system			
Stilo ST3	Vemar Helmets	BSI 6658-1985	
Stilo ST3 with SEA system	Vemar Helmets	BSI 6658-1985	
Stilo WRC	Vemar Helmets	BSI 6658-1985	Casque ouvert Open face helmet
Stilo WRC with SEA system	Vemar Helmets	BSI 6658-1985	Casque ouvert Open face helmet
Stilo WRC Carbon Piuma	Vemar Helmets	BSI 6658-1985	Casque ouvert Open face helmet
Stilo WRC Carbon Piuma with SEA system	Vemar Helmets	BSI 6658-1985	Casque ouvert Open face helmet
Stilo Trophy (Jet/Rally/Plus)	Vemar Helmets	BSI 6658-1985	Casque ouvert Open face helmet
Stilo Trophy (Jet/Rally/Plus) with SEA system	Vemar Helmets	BSI 6658-1985	Casque ouvert Open face helmet
Stilo ST4 Rally with SEA system	Vemar Helmets	Snell 2005	
LICO Top / Tecno	Vemar Helmets	BSI 6658-1985	
LICO Driver / Air Plus	Vemar Helmets	BSI 6658-1985	Casque ouvert Open face helmet





<sup>(2)</sup> L'utilisation des modèles HANS approuvés, avec les modèles de casques figurant ci-dessus, est conforme à l'Annexe L – Chapitre III – Article 1.2. du Code Sportif International. Les casques homologués selon la norme FIA 8860-2004 sont d'office compatibles avec le système HANS et ne sont donc pas listés ici.

*The use of the approved HANS models, with the helmet models as listed above, complies with Appendix L – Chapter III – Article 1.2. of the International Sporting Code. Helmets homologated according to the standard FIA 8860-2004 are compatible with the HANS system as a matter of course and are therefore not listed here.*

<sup>(1)</sup> Consultez l'Annexe L- Chapitre III- Article 1.2 du Code Sportif International pour les détails  
*Please refer to Appendix L – Chapter III – Article 1.2. of the International Sporting Code for details*



**Partie 3 / Part 3**  
**Systèmes de sangle du HANS® approuvés selon FIA 8858-2002**  
**HANS® tether system approved according to FIA 8858-2002**

Systèmes de sangle du HANS® approuvés selon FIA 8858-2002 <sup>(3)</sup> HANS® tether system approved according to FIA 8858-2002 <sup>(3)</sup>		
Fabricant / Manufacturer System description	Ancrage de sangle  Tether anchorage	Sangles  Tether
Schuberth Engineering AG  Embedded post anchorage	  No identification is shown on the tether as it is part of the approved helmet	  This label is sewn on the tether
Schroth  Post-anchorages  Also branded:  Bell OMP Point Racing Sparco Stilo	  Tether anchors are engraved with the FIA standard name  Exist in different colors	  This label is sewn on the tether The tether is made of black strap
	  Tether anchors are engraved with the FIA standard name	  Tether end fitting type SL99

<sup>(3)</sup> Les ancrages de sangle du casque d'un fabricant peuvent être accrochés indifféremment aux sangles de HANS® d'un autre fabricant, dans la mesure où ceux-ci sont mécaniquement compatibles  
*The HANS® tethers from one manufacturer can be attached equally well to the helmet tether anchorage from another manufacturer, when they are mechanically compatible.*

Systèmes de sangle du HANS® approuvés selon FIA 8858-2002 <sup>(3)</sup> HANS® tether system approved according to FIA 8858-2002 <sup>(3)</sup>		
Fabricant / Manufacturer System description	Ancrage de sangle Tether anchorage	Sangles Tether
Stand 21 Post-anchorages	 <p>Tether anchors are engraved with the FIA standard name</p> <p>Exist in different colors</p>	 <p>This label is sewn on the tether The tether is made of black strap</p>
HANS Performance Products Post-anchorages	 <p>Tether anchors are engraved with the FIA standard name</p> <p>Exist in different colors</p>	 <p>This label is sewn on the tether The tether is made of black strap</p>
	 <p>Polycarbonate tether anchorage engraved with the FIA standard name</p>	<p>Quick release tether system</p>  <p>The label is sewn on the tether</p>

<sup>(3)</sup> Les ancrages de sangle du casque d'un fabricant peuvent être accrochés indifféremment aux sangles de HANS® d'un autre fabricant, dans la mesure où ceux-ci sont mécaniquement compatibles  
 The HANS® tethers from one manufacturer can be attached equally well to the helmet tether anchorage from another manufacturer, when they are mechanically compatible.

Systèmes de sangle du HANS® approuvés selon FIA 8858-2002 <sup>(3)</sup> HANS® tether system approved according to FIA 8858-2002 <sup>(3)</sup>		
Fabricant / Manufacturer System description	Ancrage de sangle Tether anchorage	Sangles Tether
Stilo  «SEA system» Post-anchorages	 Post-anchorage washer matching helmet slots	 This label is sewn on the tether The tether is made of yellow strap
	Quick release tether system 	

<sup>(3)</sup> Les ancrages de sangle du casque d'un fabricant peuvent être accrochés indifféremment aux sangles de HANS® d'un autre fabricant, dans la mesure où ceux-ci sont mécaniquement compatibles  
The HANS® tethers from one manufacturer can be attached equally well to the helmet tether anchorage from another manufacturer, when they are mechanically compatible.